

- MATERIAL:**
MOLDING: LCP UL94 V-0
CONTACT: COPPER ALLOY.
PLATED GOLD ON CONTACT AREA,
G/F GOLD ON SOLDER AREA,
50u" NICKEL PLATING OVER ALL.
SHELL: SUS304-H,T=0.30±0.03mm
50u" NICKEL PLATING OVER ALL.
EMI SHILD: SUS304-H,T=0.12±0.03mm
LATCH: SUS301-H,T=0.15±0.03mm
- MECHANICAL:**
INSERTION: 5~20N.
EXTRACTION: 8~20N.
DURABILITY: 10000 CYCLES
- ELECTRICAL:**
CURRENT: 5A MAX FOR VBUS;
1.25A FOR GND, 0.25A FOR OTHER OTHER.
VOLTAGE: 20VDC MAX
WITHSTANDING VOLTAGE: 100V AC.
CONTACT RESISTANCE: 40mΩ MAX.
INSULATION RESISTANCE: 100MΩ MIN.
- ENVIRONMENTAL**
TEMPERATURE RANGE: -30°C TO +80°C

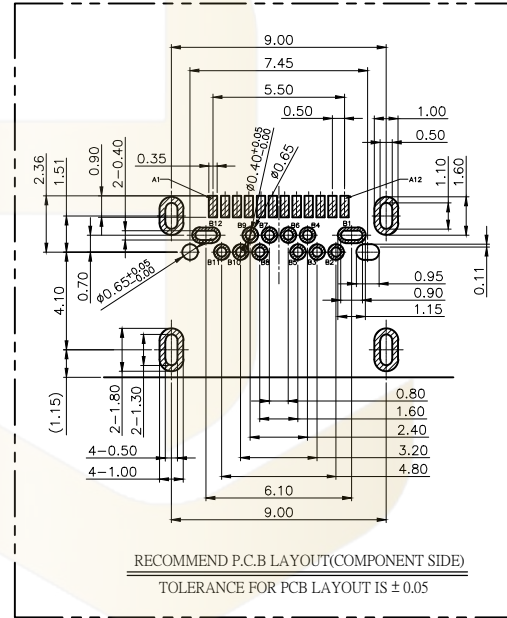
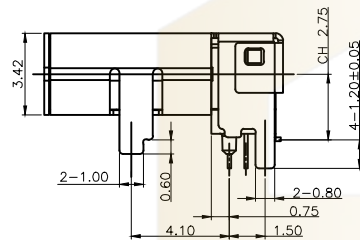
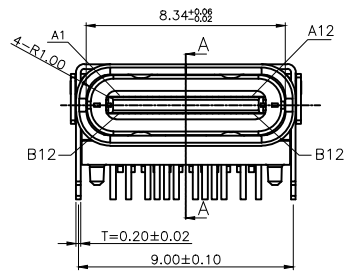

USB TYPE-C PIN ASSIGNMENTS

PIN NUMBER	SIGNAL NAME	PIN NUMBER	SIGNAL NAME
A1	GND	B12	GND
A2	SSTXP1	B11	SSRX1
A3	SSTXN1	B10	SSRXN1
A4	VBUS	B9	VBUS
A5	CC1	B8	SBU2
A6	Dp1	B7	Dn2
A7	Dn1	B6	Dp2
A8	SBU1	B5	CC2
A9	VBUS	B4	VBUS
A10	SSRXN2	B3	SSTXN2
A11	SSRX1	B2	SSTXP2
A12	GND	B1	GND

P/N	L	B	F 脚长	COLOR	额定电流
HC-TYPE-C-24P-DSS-65-CH2-75S-5A-04	8.65mm	4.85mm	1.20mm	黑色	5A
HC-TYPE-C-24P-DS10.0-CH2-75S-5A-04	10.00mm	6.20mm	1.20mm	黑色	5A

Ordering Information

HC-TYPE-C - 24P - *** - S - **A - F* - * - 04

Pin 4P 6P 9P 12P 15P 24P
 (Pin 4P 6P 9P 12P 15P 24P)
 Type: M=Top Mount (18.0), D=DP=DP Mount (18.0), M=Mid Mount (18.0), C=Center Mount (18.0), V=Vertical Mount (18.0), DP=DP Mount (18.0), F=Top Mount (18.0)
 Current Rated: 5A
 Foot Length: 1.20mm
 Colour: B=Black, W=White, G=Green, O=Orange, P=Purple, Y=Yellow

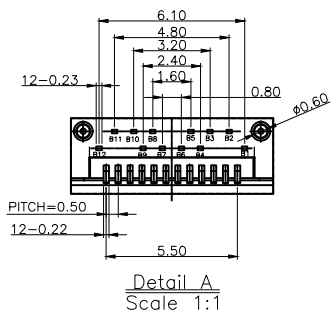
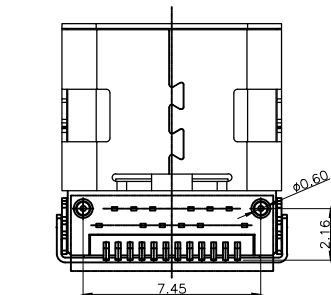

GENERAL TOLERANCE		制图	审核
DIM	TOL	DRAWING	CHECK
X.X	±0.30	批准	APPROVAL
X.XX	±0.20	比例	SCALE
X.XXX	±0.10	投影	Projection
Angle	±3.0°		

深圳市华灿天禄电子有限公司
Shenzhenhuacantianlu ELECTRONICS CO., LTD

产品名称	TITLE	版本	REV.
TYPE CF 24P 前插后贴+垫高2.75	TYPE CF 24P 前插后贴+垫高2.75	版本	A
产品料号	PART NO.	单位	UNITS
双壳 L8.65/10.00mm 带柱无弹	HC-TYPE-C-24P-DSX-CH2.75S-5A-04	单位	mm
材料	MATERIAL	页次	SHEET
		页次	1/2

pcs/box	boxes/Carton	Pcs/Box
700	10	7000

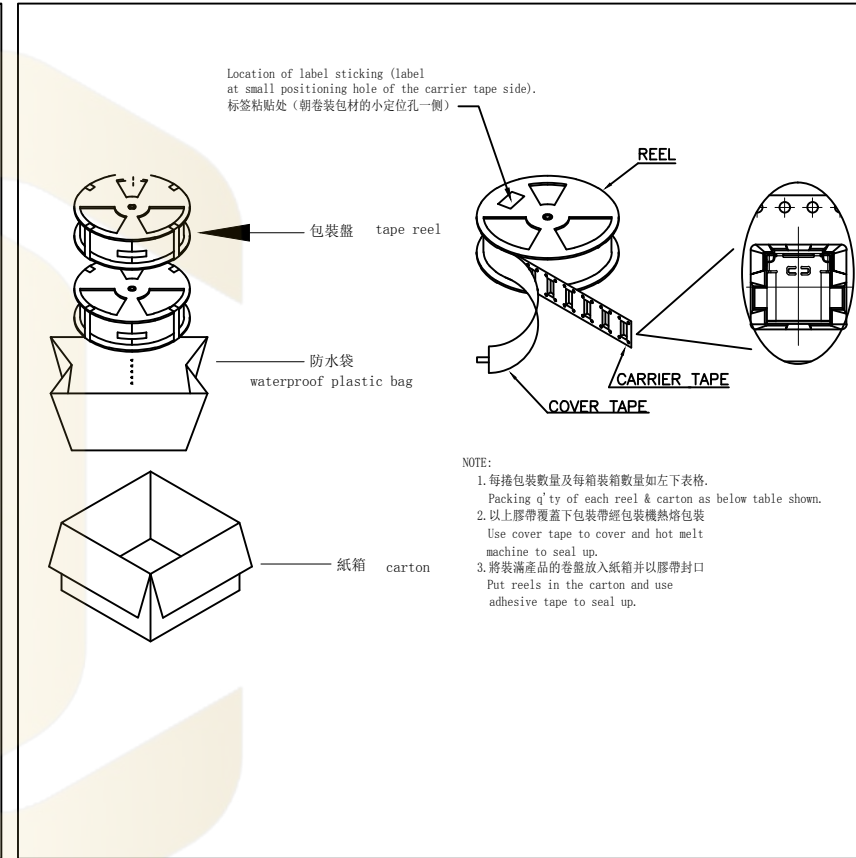
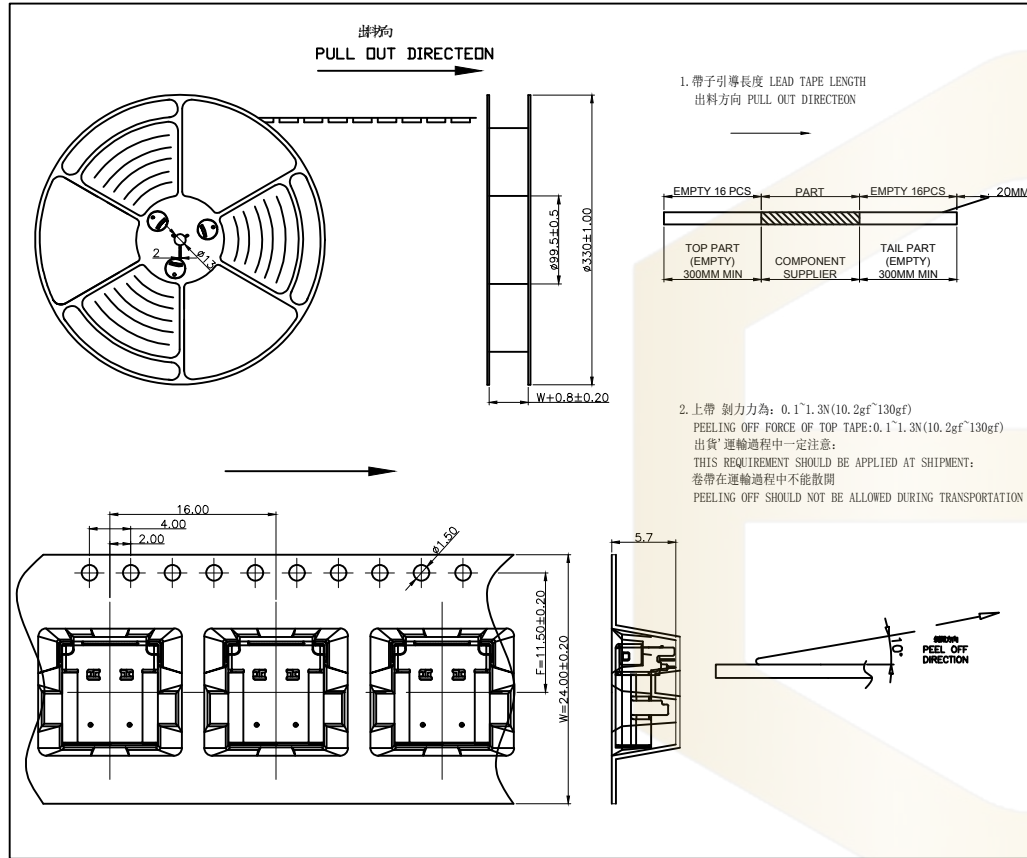

			GENEAL TOLERANCE	制 圖 DRAWING	深圳市华灿天禄电子有限公司 ShenzhenhuacantianluELECTRONICS CO., LTD			
			DIM TOL	审 核 CHECK	产 品 名 称 TITLE	TYPE CF 24P 前插后贴+垫高2.75 双壳 L8.65/10.00mm 带柱无弹-包装图	版 本 REV.	A
			X.X ±0.30	批 准 APPROVAL	产 品 料 号 PART NO.	HC-TYPE-C-24P-DSX-CH2.75S-5A-04	单 位 UNITS	mm
			X.XX ±0.20	投 影 Projection	材 料 MATERIAL		页 次 SHEET	2/2
			X.XXX ±0.10					
			Angle ±3.0°					
1	初版发行							
序号 No.	变更内容 MODIFY CONTENT	日期 MODIFY DATE						