

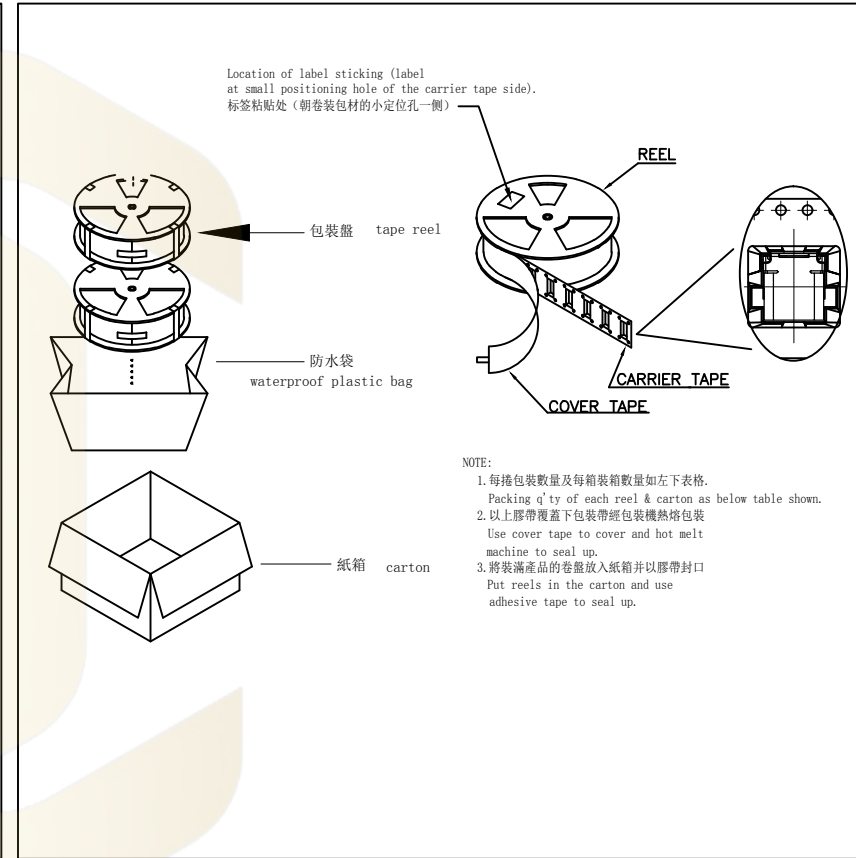

pcs/box	boxes/Carton	Pcs/Box
1000	10	10000

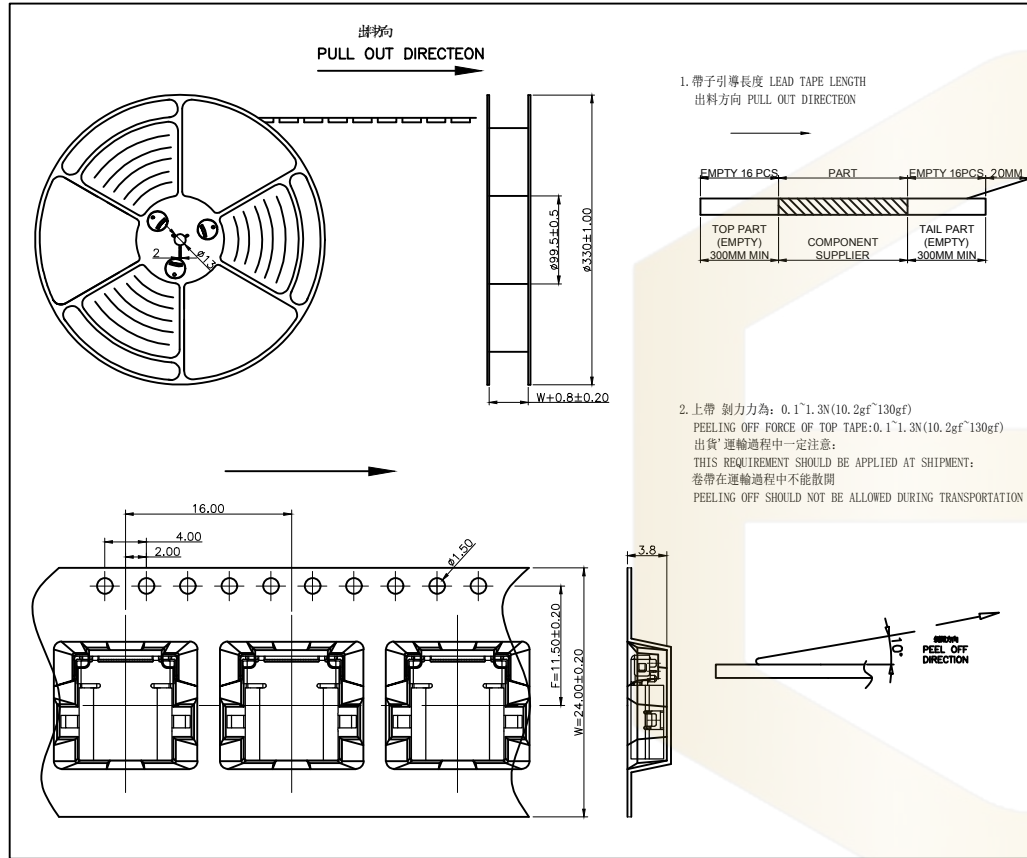

			GENREL TOLERANCE		制 圖 DRAWING		 深圳市华灿天禄电子有限公司 ShenzhenhuacantianluELECTRONICS CO.,LTD			
			DIM	TOL	审 核 CHECK					
			X.X	±0.30	批 准 APPROVAL		产品名称 TITLE	TYPE CF 24P 前插后贴+沉板 CH0.33 L8.65/10.00mm 带柱无弹 -包装图	版本 REV.	A
			X.XX	±0.20	比 例 SCALE		产品料号 PART NO.	HC-TYPE-C-24P-DSX-MM0.33-5A-04	单 位 UNITS	mm
			X.XXX	±0.10	投 影 Projection		材 料 MATERIAL		页 次 SHEET	2/2
序号 No.	变更内容 MODIFY CONTENT	日期 MODIFY DATE	Angle	±3.0°						